

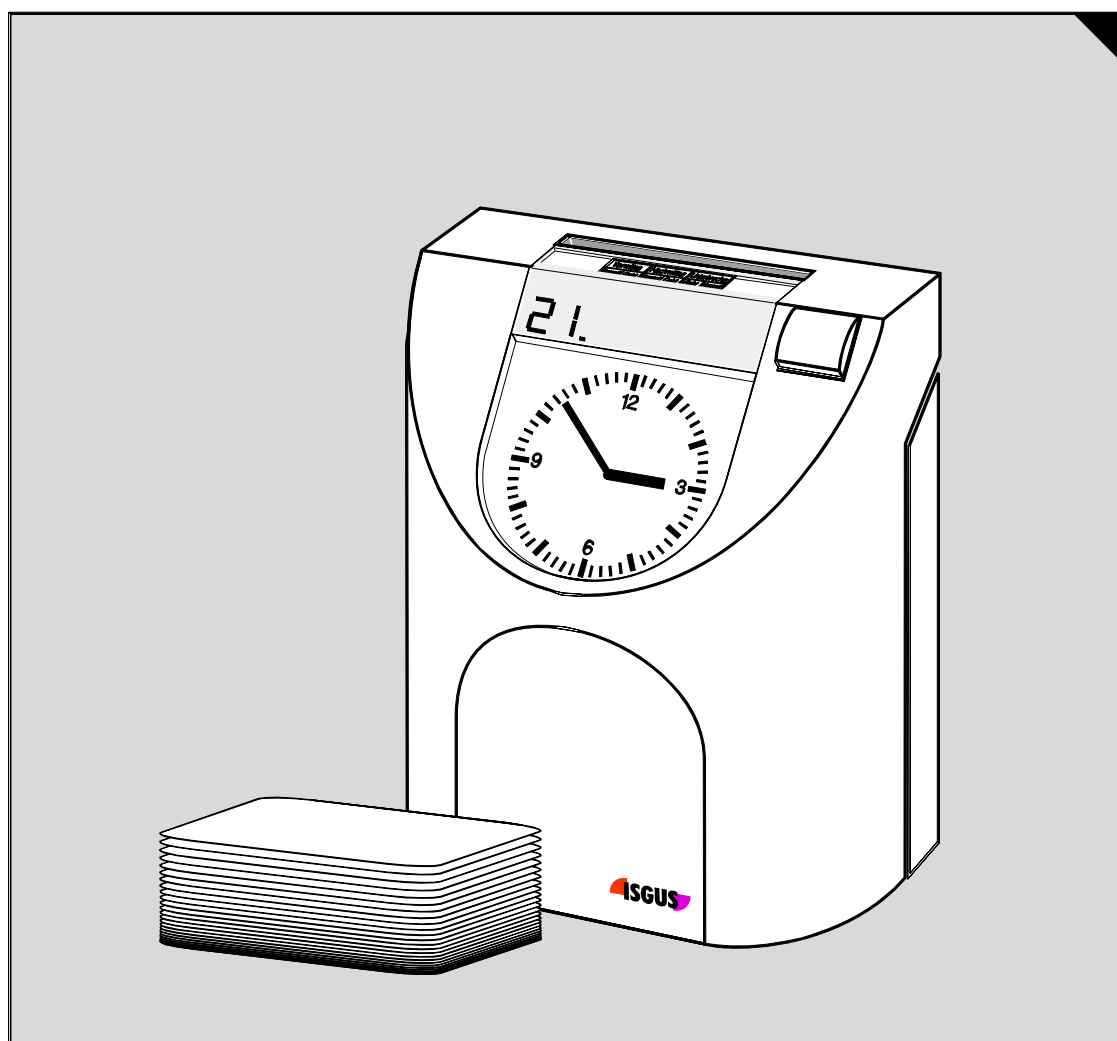

# ***PERFECT 2020***



**Operating and Installation Manual**



# PERFECT 2020

## Time recorder

### Manual for the operation and installation of the time recorder.

#### Copyright © 2009 ISGUS GmbH

The company ISGUS GmbH claims copyright protection for this documentation. No part of this documentation may be amended, extended, reproduced or by any means of infringement on other legitimate interests without the prior written permission of ISGUS.

With the exception of component parts changes, ISGUS has made every effort to keep the contents of this manual current and correct at the time of publication. However, we cannot guarantee the documentation to be 100% accurate.

Should you find any errors in this document, please let us know.

We are always grateful for suggestions and comments from our customers.

Edition                      008CA. 0809 00 BA 40

Printed in Federal Republic of Germany

Ref. No.                      7140

ISGUS GmbH  
Oberdorfstraße 18-22  
DE - 78054 Villingen-Schwenningen

[www.isgus.de](http://www.isgus.de)  
[info@isgus.de](mailto:info@isgus.de)



## WARNING

This Equipment has been tested and found to comply with the limits for a Class B digital device, pursuant to Part 15 of the FCC Rules.

These limits are designed to provide reasonable protection against harmful interference in a residential installation.

This equipment generates, uses and can radiate radio frequency energy and, if not installed and used in accordance with the instructions, may cause harmful interference to radio communications.

Only peripherals certified to comply with the Class B limits may be attached to this equipment.

However, there is no guarantee that interference will not occur in a particular installation.

If this equipment does cause harmful interference to radio or television reception, which can be determined by tuning the equipment off and on, the user is encouraged to try to correct the interference by one or more of the following measures:

- Reorient or relocate the receiving antenna.
- Increase the separation between the equipment and receiver.
- Connect the equipment into an outlet on a circuit different from that to which the receiver is connected.
- Consult the dealer or an experienced radio/TV technician for help.

# Safety instructions

## Designated use

- The PERFECT 2020 time recorder is exclusively designed for the printing of time and date information on manufacturer approved time cards, which is the only designated use of this machine, as described in this manual.
- Using the time recorder for purposes other than that described above is considered contrary to its designated use. The manufacturer cannot be held liable for any damage resulting from such use. The risk of misuse of the time recorder lies entirely with the user.
- The time recorder has no explosive environment protection. The use of the recorder in an explosive hazardous area is contrary to its designated use. The manufacturer and/or dealer cannot be held liable for any damage resulting from installation and use of the time recorder in such areas.
- Operating the time recorder within the limits of its designated use requires that you follow the instructions set out in the operating manual.
- All service work on the time recorder must be done by trained technicians who are familiar with the time recorder and have been instructed in safety precautions.
- All applicable local and national safety regulations must be observed in the installation, use, and maintenance of the time recorder.
- Modifications to the time recorder made without the authorization of the manufacturer will negate the manufacturer's responsibility and liability.

## Hints for the user

- Before installing and programming the time recorder, the operator must read the operating instructions and safety notes.
- The time recorder should only be opened by competent and trained personnel.
- The external power supply must be unplugged during maintenance and repair. The person performing the service must also ensure that all wiring entering or leaving the time recorder is electrical current-free before beginning work.
- Improper changing of the lithium battery may result in explosion. Do not use batteries other than those specified by the manufacturer. Send the replaced batteries to the recycling process available in your area.
- Any additional changes or service to the electrical components of the unit must be carried out by a qualified electrical technician.
- In addition to reading the operating instructions, the user should be instructed in all other generally applicable legal and other mandatory regulations relevant to accident prevention and environment protection.

## Hints for the recorder's safety

- The time recorder has been built to the highest standards and conforms to recognized safety rules. Nevertheless, its use may constitute a risk to the user or third parties, or cause damage to the unit and to other property.
- Operate the time recorder only with the power supply being part of the time recorder package.
- The time recorder must only be used in a suitable environment, in accordance with its designated use and the instructions set out in this operating manual. Any equipment or functional problems, especially those affecting the safety of the unit and users of the unit, should be repaired immediately.
- Replacement parts must comply with the technical requirements specified by the manufacturer. This is guaranteed only when you use the manufacturer's original replacement parts. Use of non-conforming parts voids your warranty.
- Unplug and switch the unit off immediately if a problem occurs in the electrical system.
- Installation and mounting of the unit must be done by trained personnel.
- Plug the time recorder power supply into a sufficiently grounded electrical outlet.
- Ensure that all consumables and replaced parts are disposed of safely and with minimum environmental impact.



### **Warning!**

This symbol focuses the user's attention to special procedures and in the handling of the time recorder that could cause serious injuries if the instructions are not followed carefully.



### **Attention**

This symbol indicates that there may be danger to the time recorder if the text is not read or the procedure is not followed. Data may be lost or the recorder may be damaged.

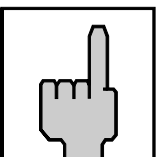

### **Hint**

This symbol indicates useful information and recommendations for the handling of the time recorder.

---

## Table of Contents

<b>Product Overview .....</b>	<b>2</b>
<b>Time Recorder Specifications .....</b>	<b>3</b>
<b>Contents .....</b>	<b>4</b>
<b>Selecting a Location.....</b>	<b>5</b>
General Conditions .....	5
Specific Conditions for the Time Recorder .....	5
<b>Time Recorder Installation.....</b>	<b>6</b>
Installation for Table Operation .....	6
Wall Mounting .....	7
Open the Recorder .....	8
Close the Recorder.....	9
Remove the Metal Back Plate .....	9
Wall Mounting.....	10
Connect the Power Supply .....	10
Connect Optional Features.....	12
<b>Getting Started.....</b>	<b>14</b>
Switch on the Unit.....	14
Programming Panel.....	15
Setting the Time and Date .....	18
Showing or Setting the Time of the Internal Quartz Clock.....	20
Synchronizing the Analogue Clock .....	21
Setting the Date.....	21
<b>Programming .....</b>	<b>22</b>
Calling up the Programming Routine.....	22
Daylight Saving Time Change-over .....	23
Column Change Timing.....	25
Card Lift / Line Change timing .....	27
Ribbon Color Change .....	28
Signal Operation .....	30
Signal out-programming .....	32
Check of individuals (Option).....	33
<b>Punching at the Recorder .....</b>	<b>34</b>
Punching with Standard Time Cards.....	35
Standby Operation (Option).....	35
<b>Change of Fuse for Signal Output.....</b>	<b>36</b>
<b>Error messages.....</b>	<b>37</b>
<b>Adjustment Routine.....</b>	<b>38</b>
Card lift / Line change.....	38
Column change .....	38
<b>Changing the Ribbon.....</b>	<b>39</b>
<b>Cleaning the Time Recorder .....</b>	<b>40</b>
<b>Technical Specifications.....</b>	<b>41</b>
<b>Local Sales and Service Dealer.....</b>	<b>42</b>

---

## Product Overview

The PERFECT 2020 is an electronic time recorder used for the printing of employee time and attendance records. The time recorder can be programmed by the user to suit many different work schedules.

Your ISGUS time recorder is equipped with the following features to simplify time recording in your company:

- Real time clock, quartz controlled with battery back-up
- Synchronized analogue display clock with power reserve
- Automatic changing of daylight-saving-time (when programmed)
- Automatic adjustment for leap year
- Large selection of pre-defined card formats
- Large selection of defined print formats
- Two color print programmable
- Signal circuit
- Automatic column selection
- Check of individuals

The PERFECT 2020 prints the time and day automatically when the employee inserts a time card into the card funnel. The positioning of the printed time on the time card is done automatically by the time recorder.

A number of standard card formats are available and can be selected from the programming routine. The card format is generally determined by the pay period frequency of your company.

In order to guarantee the reliability of the time recorder, each unit has been tested thoroughly before leaving the factory. If there are any problems that cannot be resolved using this manual, please contact your local dealer or e-mail us at:

**[support@ca.isgus.com](mailto:support@ca.isgus.com)**

or

**[techsupport@isgus.com](mailto:techsupport@isgus.com)**

This manual provides step-by-step instructions for the handling of the time recorder. Before using the time recorder, please read the manual carefully and pay close attention to all safety instructions.

---

## Time Recorder Specifications

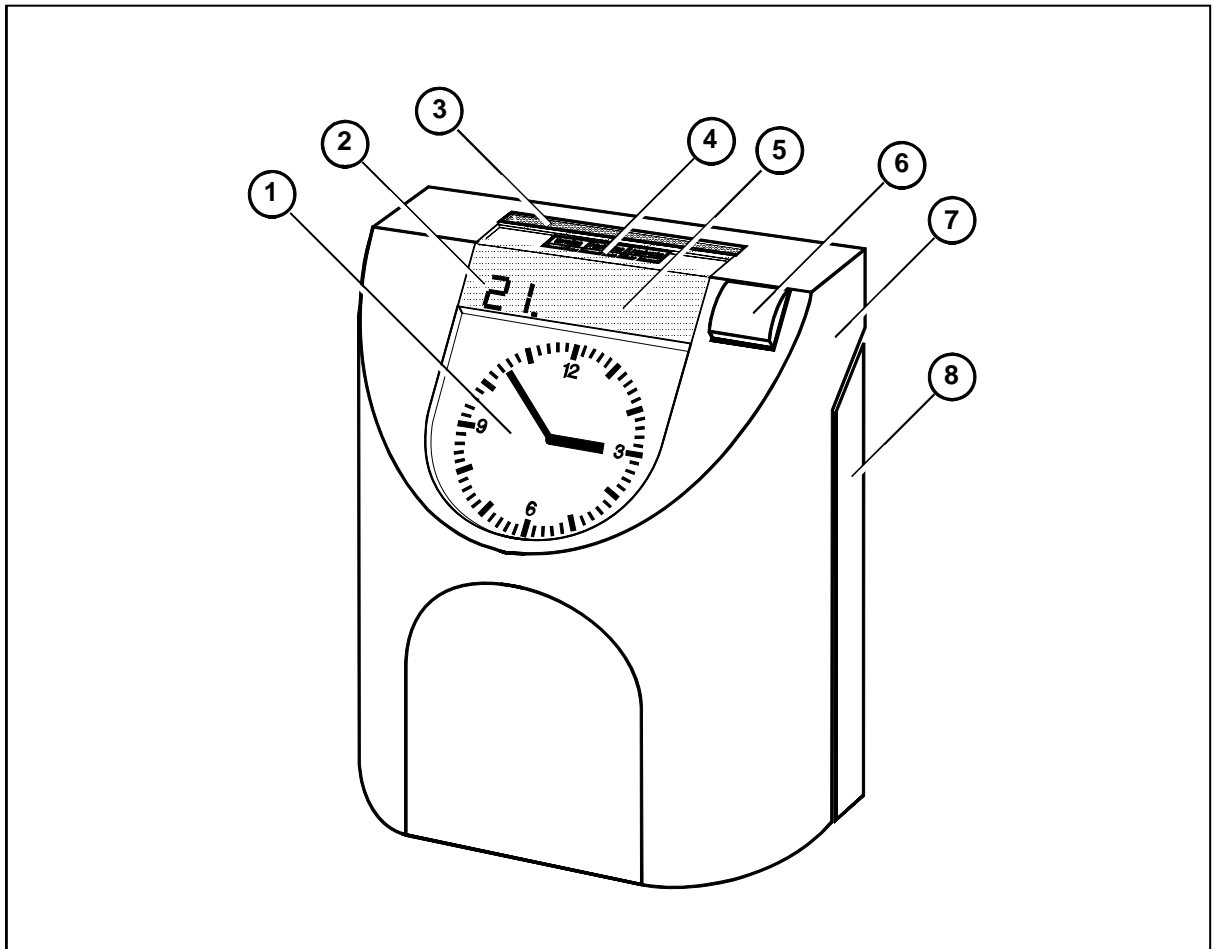

Fig. 1: Total view

- (1) Analogue clock
- (2) Digital date display (also used for programming)
- (3) Card funnel
- (4) Pointer field with funnel label and column pointer
- (5) Programming Panel, concealed by the front cover  
→ see section "Getting Started"
- (6) Position key
- (7) Front case cover
- (8) Rear case cover

The name-plate with type of unit and electrical data is attached to the bottom of the cover. The serial-no. is located inside the unit on the bottom.  
The program release with date and type of recorder is found on the label on the memory IC of the PC-board.

---

## Contents

The following illustration shows the time recorder box contents without options.

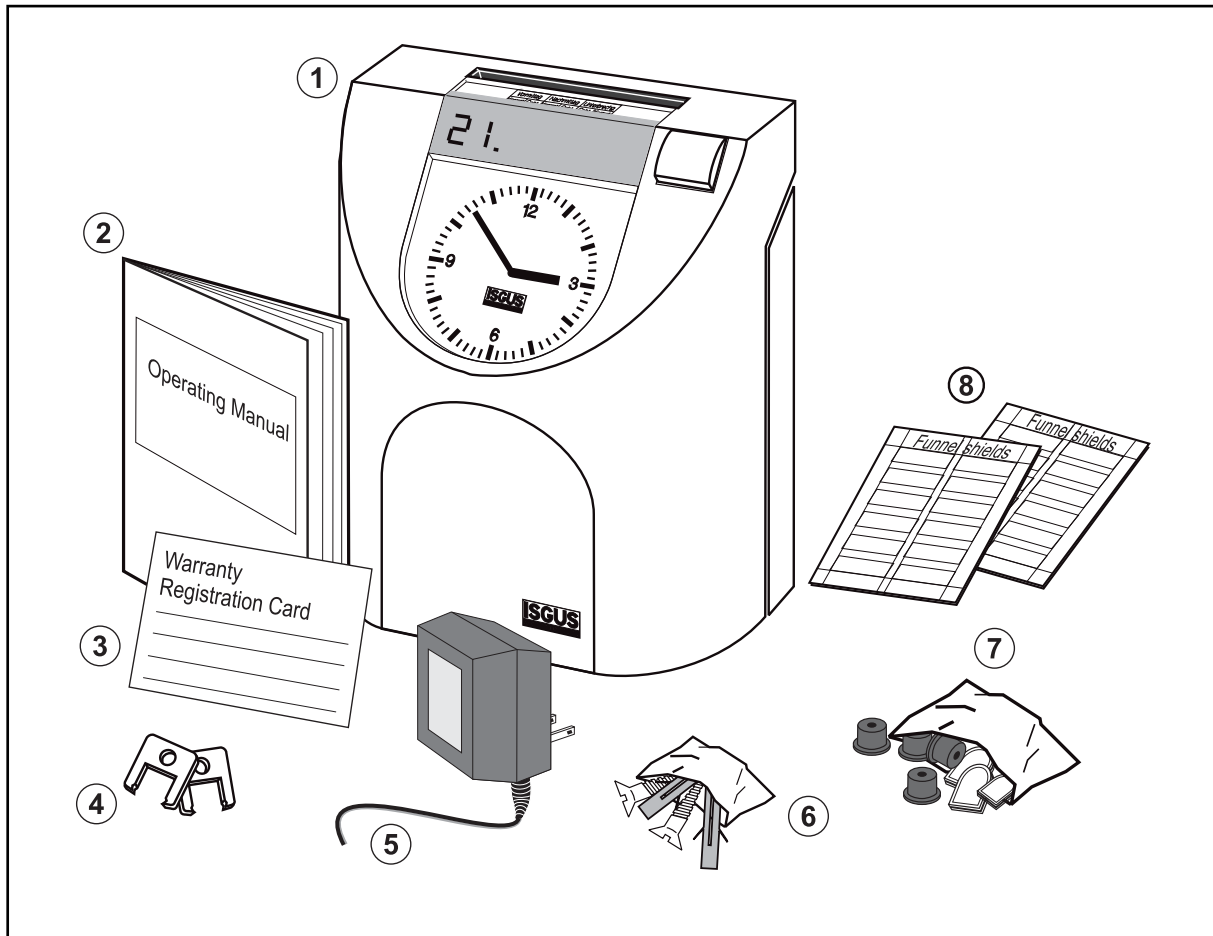
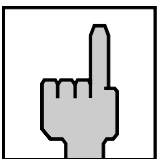

Fig. 2: Supply

- (1) Time recorder PERFECT 2020
- (2) Operating manual
- (3) Warranty Registration Card
- (4) 2 keys
- (5) Power supply unit
- (6) Fixing elements for wall mounting (2 screws, 2 plugs)
- (7) Set of accessories for table operation (4 rubber feet, 3 cover caps)
- (8) Set of funnel shields



### Hint

Time cards are not included with your time recorder and must be ordered separately. Please contact your local dealer or e-mail us at:

**[sales@ca.isgus.com](mailto:sales@ca.isgus.com)**

or

**[sales@isgus.com](mailto:sales@isgus.com)**

---

---

## Selecting a Location

---



### **Warning!**

Proper installation of the time recorder is the responsibility of the owner. All work must only be carried out by qualified personnel. The installation must comply with the requirements of the authorities having jurisdiction and all applicable safety codes and regulations that govern the installation of electrical appliances.

---

---

### **General Conditions**

The installation location should have the following characteristics:

- the time recorder is not exposed to electrical frequency transmissions
- the time recorder is not exposed to direct sunlight.
- the location's environment is within the temperature and humidity limits published in this manual.
- the location is free of airborne particles such as dust, dirt and fine powders and there is no possibility of the time recorder being exposed to direct contact with any kind of liquid or steam.
- there are no dirty manufacturing processes that could contaminate the location .
- the location is isolated from electromagnetic noise sources such as motors, electromagnets, and series reactors.

---

### **Specific Conditions for the Time Recorder**

- The time recorder is designed for continuous operation.
- The time recorder is designed for indoor mounting only. Outdoor mounting is not supported. Avoid direct sunlight and high humidity (refer to "Technical Specifications, Appendix A").
- Connection only to the mains voltage specified on the name-plate.
- Cable connections must not be permanently installed.
- Only use the recorder with the supplied power supply unit, both in table and wall mount installations.
- In the power supply installation in the building a separator, e.g. fuse, switch, etc. must be integrated to allow a contact opening of at least 3 mm per pole.
- Installation must be according to NEC requirements

---

## Time Recorder Installation

Basically the PERFECT recorder is designed for table operation. No further settings are required for this type of application. Please see the instructions in the following section "Installation for table operation". If you have to connect additional functions such as signal operation, or master or slave clock operation, refer to the end of section "Wall mounting".

For wall mounting refer to the corresponding section "Wall mounting". When used as wall-mounted recorder you have to carry out a number of installation steps described in this chapter.

The connection of additional options and the programming of the time recorder are carried out with the time recorder's case open. Below the time display panel you will find a power switch and other electrical terminals and components. Please refer to the section "Programming panel".



### **Warning!**

All work must only be carried out by qualified and authorized personal.

---

---

## Installation for Table Operation

When using the time recorder as a table model, the installation effort is reduced to a minimum. Simply connect the power supply to the recorder and then plug it in to the closest receptacle. Switch on the black power switch located on the PC board. For instructions on how to switch the recorder on see section "Getting Started".

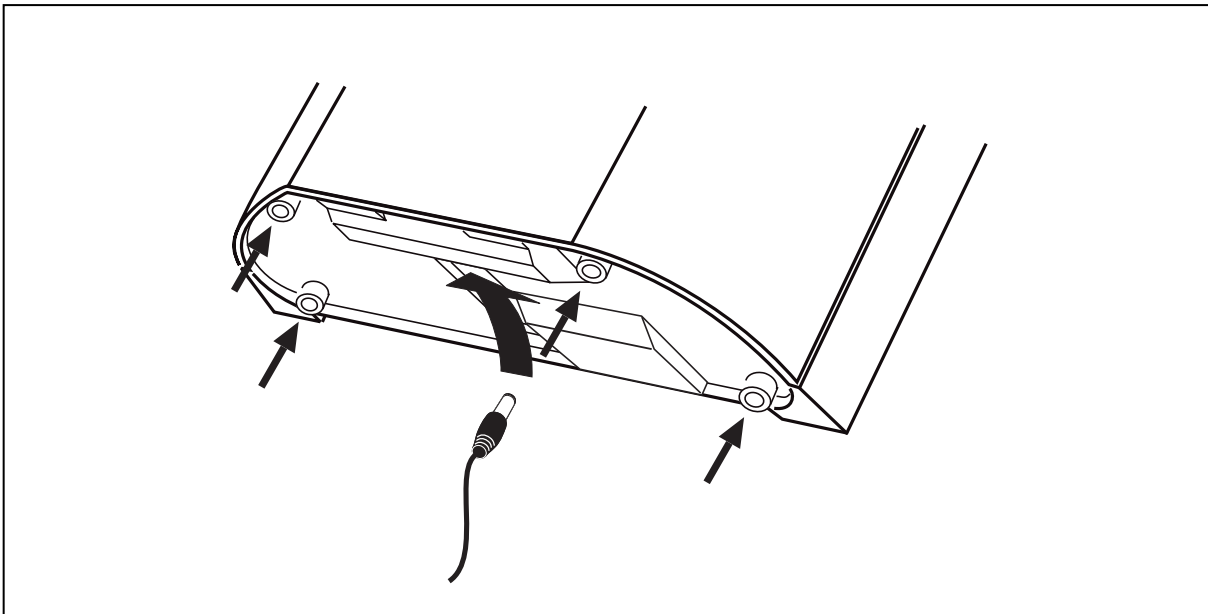

Fig. 3: Bottom side of the recorder with rubber feet and mains cable socket

Select an easily accessible and vibration-free place of installation. The recorder may only be placed on a stable, slip-resistant surface.

For the stability of the time recorder use the rubber feet included in the set of accessories. For this purpose clip them on by following the arrow-head indications.

Also use the 3 cover caps for the metal back plate in order to seal the cable leadings.

The power outlet has to be close to the recorder and easily accessible. Lay the power cable so that access is not obstructed and persons are not endangered.



### **Warning!**

Only use the time recorder with the enclosed power supply both in case of table operation and of wall mounting. Do not use extension cords.

## **Wall Mounting**

The PERFECT time recorder is designed for table mounting. However, 120 VAC power connection and signal control terminals have been provided to meet the requirements of eventual wall mounting applications.

Installation steps:

- 1. Open the time recorder**
- 2. Remove the metal rear panel**
- 3. Mount the time recorder on the wall**
- 4. Connect the power supply**
- 5. Connect any additional functions (if required)**
- 6. Getting Started**

The location of the mounting holes can be traced from the metal back plate of the time recorder. The metal back plate can be plugged in with the plastic housing.

The installation dimensions shown in the figure on the right are recommendations which can be adjusted to the local conditions. The dimensions apply both for table operation and for wall mounting.

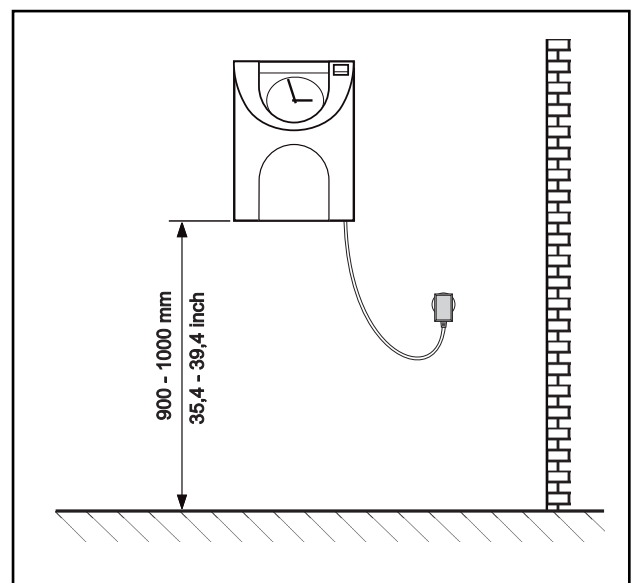

Fig. 4: Installation dimensions

---

## Open the Recorder

1. Insert the key into the slot on the under side of the time recorder. Press the key into the slot until the locking latch releases the front case cover.

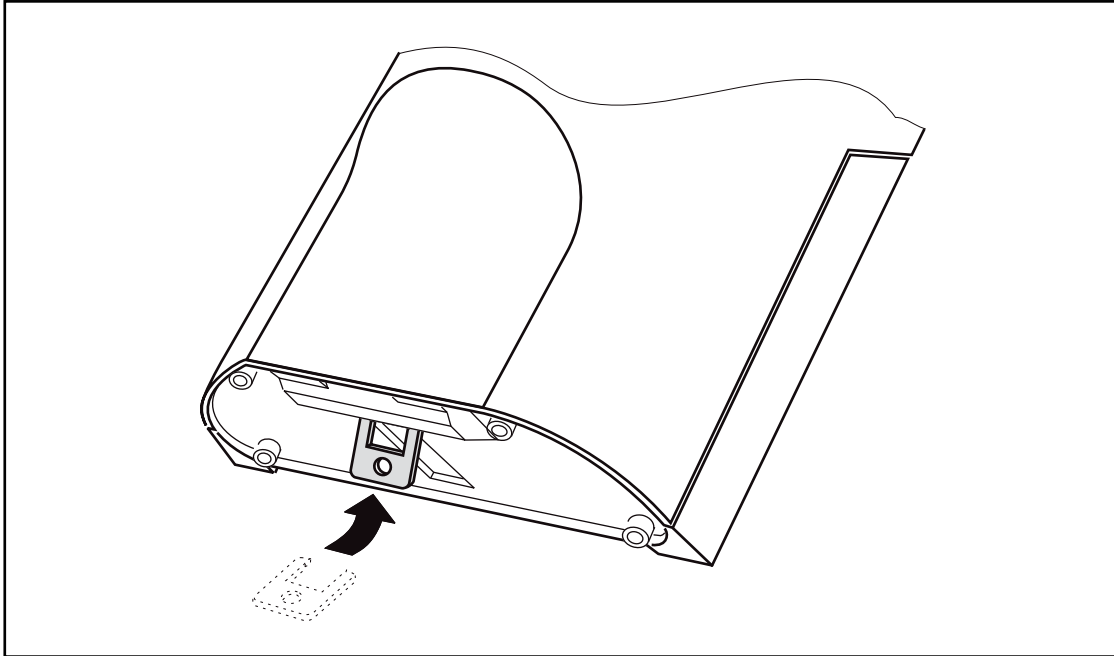

Fig. 5: Unlock the recorder

2. Swing out the front case cover with the time recorder tilted away from you (step 1) until it can be lifted up and off the time recorder (step 2).

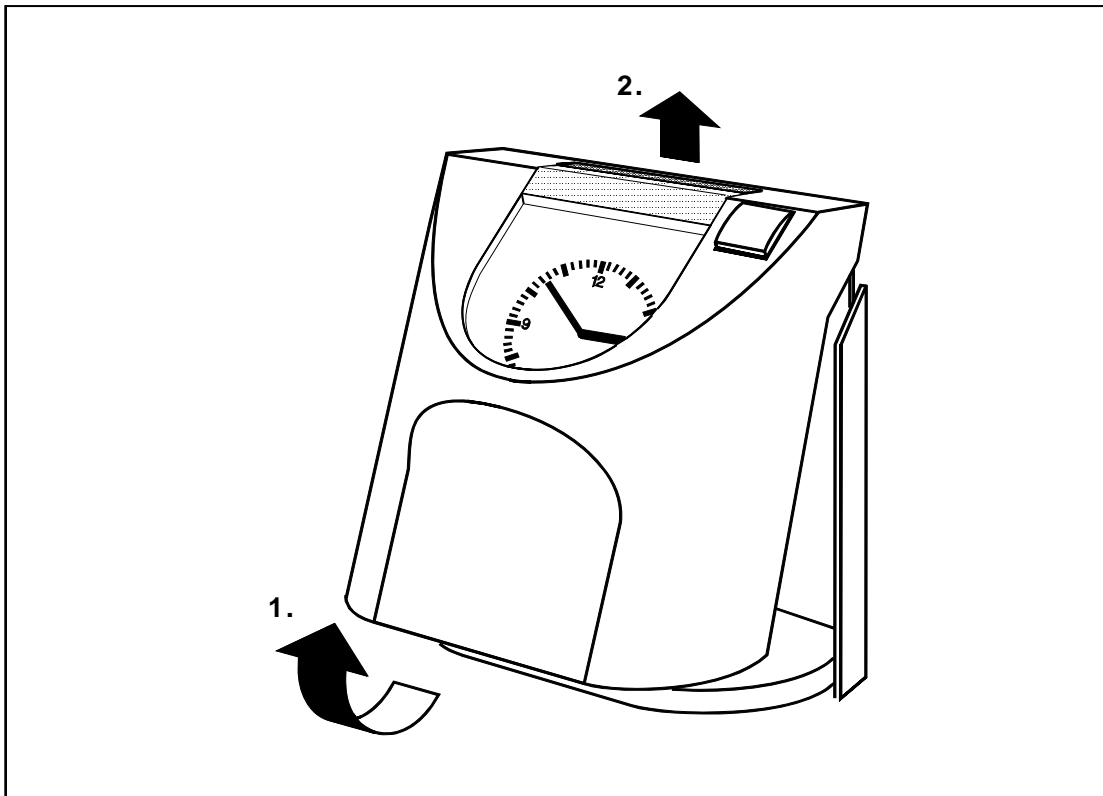

Fig. 6: Open the recorder

## 8 Time Recorder Installation

---

## Close the Recorder

1. Align and insert on an angle the two tabs at the top of the rear case cover into the corresponding two slots at the top of the front case cover.
2. Swing the front case cover downwards until it meets the bottom of the rear case cover. Push the bottom of the front case cover until it engages the locking latch on the bottom of the rear case cover.

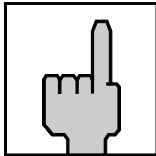

### Hint

Do not close the time recorder until you have made all electrical connections and completed all time recorder programming.

---

---

## Remove the Metal Back Plate

1. To begin removing the metal back plate, press the two locking tabs located on the top left and right hand sides of the rear case cover (step 1).
2. Keep the locking tabs pressed in and push the metal back plate back about ½ of an inch (step 2).
3. Pull the metal back plate away from the unit (step 3).

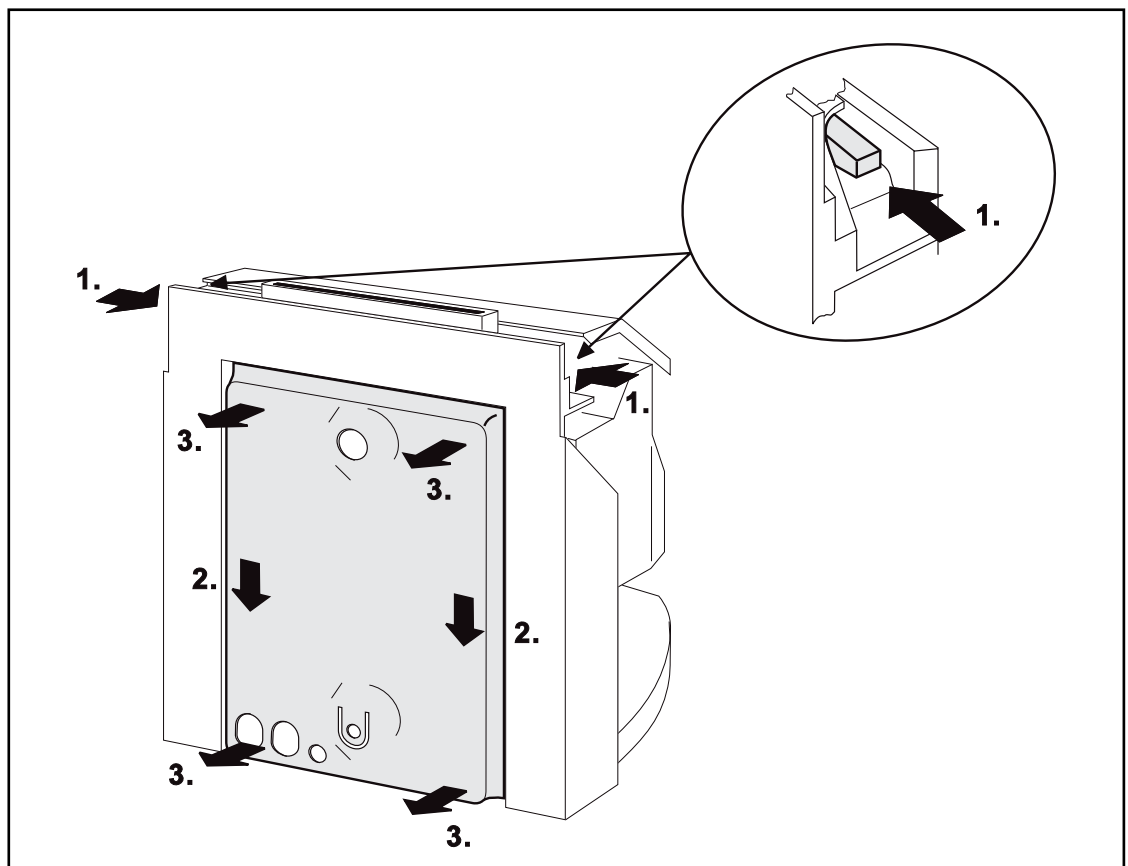

Fig. 7: Rear view of the recorder with metal back plate

---

## Wall Mounting

The location of the mounting holes can be traced from the metal back plate of the time recorder. The metal back plate can be plugged in with the plastic housing. See previous section. The installation dimensions mentioned in this manual are recommendations which have to be adjusted for local conditions.

1. Position the metal back plate in the desired wall location. Make sure the back plate is level by using a carpenter's level
2. Using a pencil, trace the upper and lower mounting holes of the metal back plate on the wall. Drill corresponding holes with a 5/16" drillbit . Insert the wall plugs.
3. Mount the metal back plate starting first with the lower screw and then the top screw. Make sure you do not fully tighten.
4. Using a carpenters level, align the time recorder once more and then tighten both screws.
5. Hang the time recorder mechanism on the wall mounted metal back plate. The four metal tabs (one on each corner of the metal back plate) must be aligned and inserted into the corresponding slots of the rear case cover. When the cover has been inserted correctly on the metal tabs, pull time recorder slightly downwards until the locking mechanism engages.

Check your installation for good fits.

---

## Connect the Power Supply

1. Make sure that the recorder has been switched off.

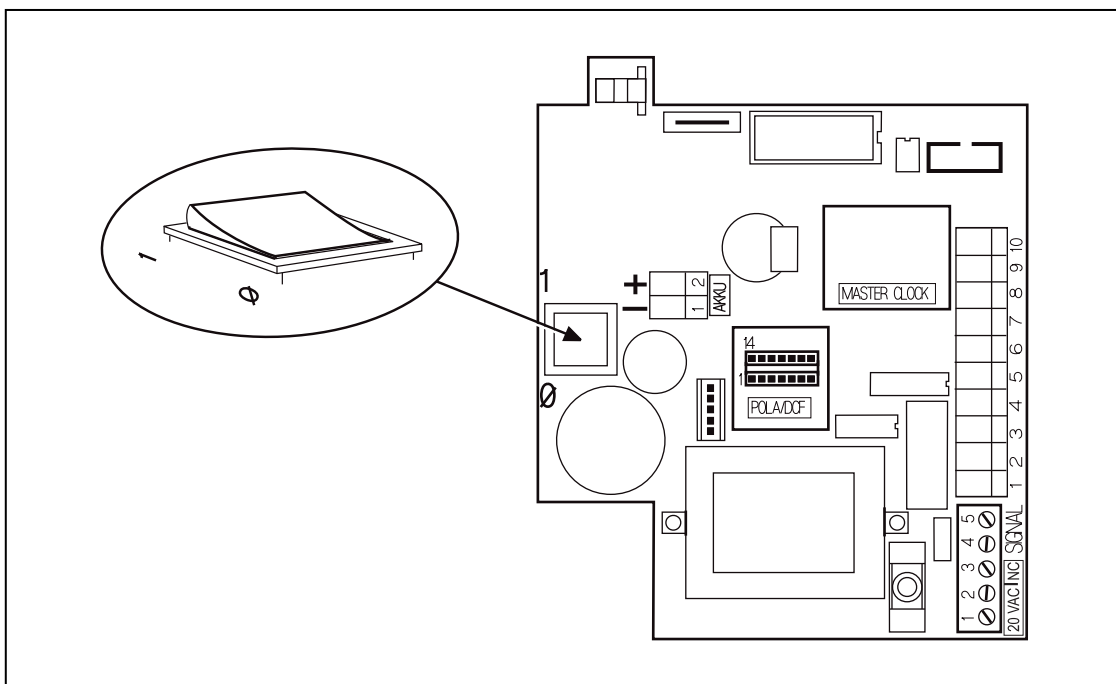
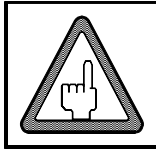
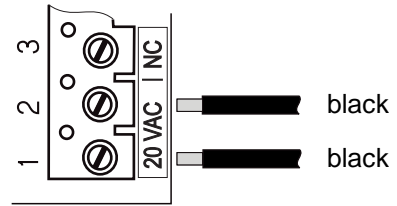

Fig. 8: PC-board with power switch

2. Check the connection of the power cord to the screw-type terminal strip of the CPU.



**Attention**

The power cord must be connected to the PC board terminals that are electrically compatible with the supply voltage of the electrical outlet that the power cord is plugged into. Incorrect connections can cause the destruction of the time recorder!

3. Connect the power cable of the power supply unit to the bottom side of your PERFECT.

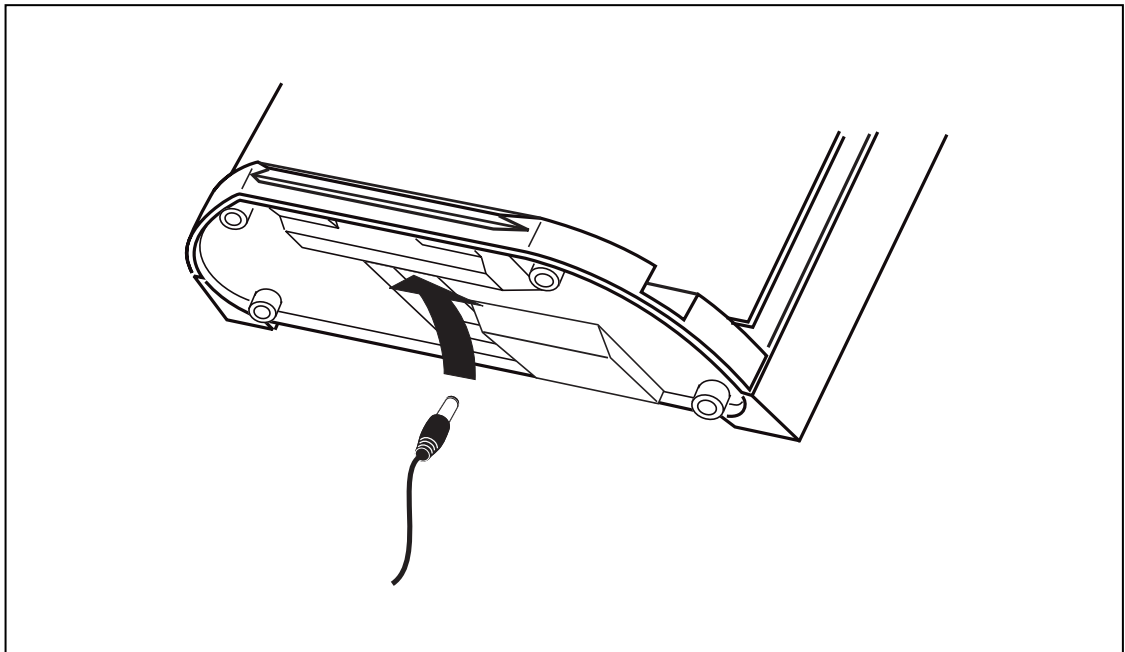

Fig. 9: Bottom side of the recorder with power cable socket

4. Insert the plug-in power supply unit into the provided socket.



**Warning!**

The power outlet must be close to the recorder and easily accessible. Make sure, that a loose power cable does not cause obstruction or risk to people.

---

## Connect Optional Features

Only connect optional features when they are required.

Optional features:

- Signal operation / Check of individuals
- Master clock operation
- Standby operation
- Slave clock operation

All optional features can be used for both types of installation, i.e. table or wall mounted version.

When used as a table unit, the knockouts at the bottom of the metal rear back plate have to be used for cable entry.

For wall mounted units the plastic knockouts on the bottom of the rear cover have to be detached.

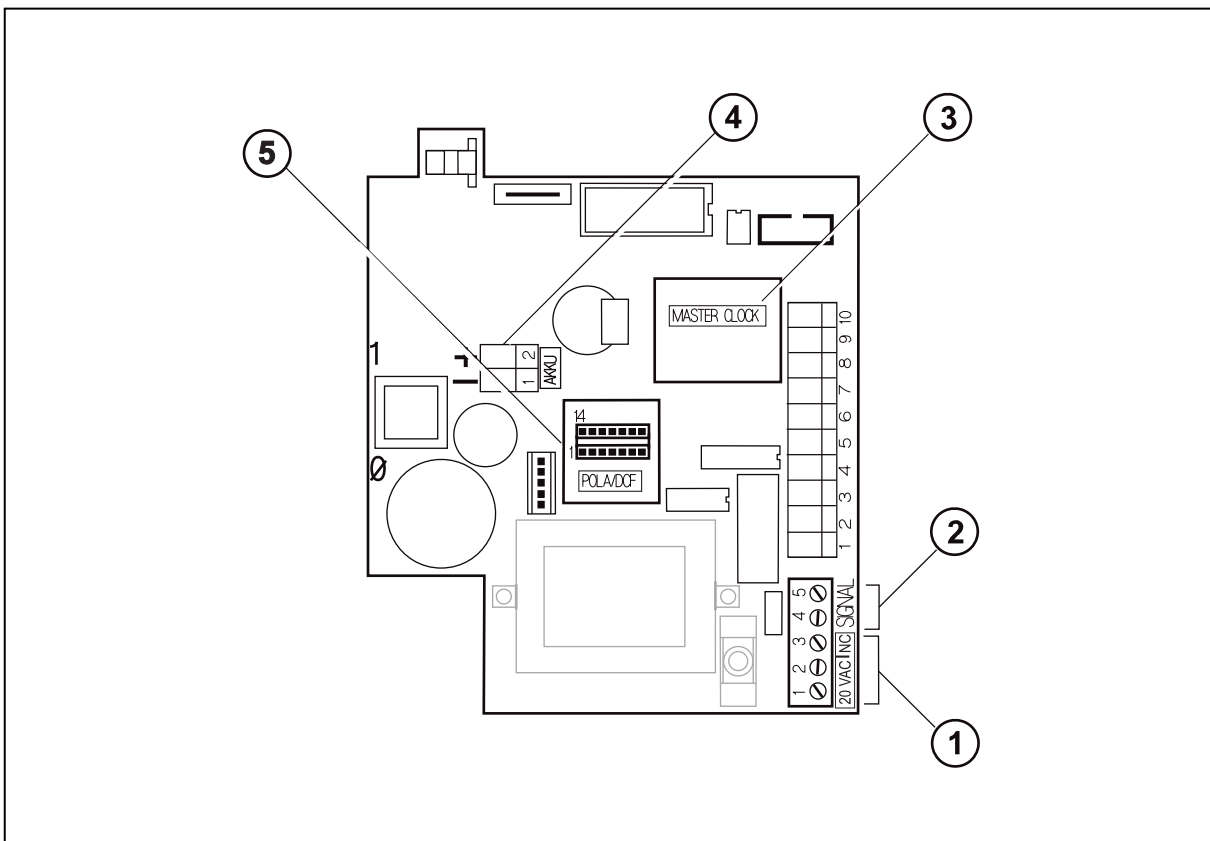

Fig. 10: PC-board with connection options

- |   |                               |
|---|-------------------------------|
| (1) Power connection terminals          | (4) Battery standby connector |
| (2) Signal circuit connection terminals | (5) Slave clock connector     |
| (3) Synchronized clock connector        |                               |

### Connect wiring for audible signal circuit control

(Signal circuit / Check of individuals

→ only if required.

→ low power signal output: 15 V DC, 50mA

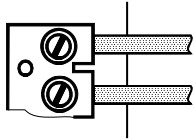

This connection is not polarity sensitive.

### Connect wiring for synchronized clock option

→ only if the recorder is equipped with the option module "MASTER CLOCK".

→ fused output rated at 12 V, max. 50 mA,

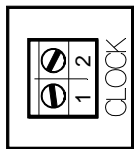

This connection is not polarity sensitive.

### Connect an optional battery pack for printer operation during a power failure.

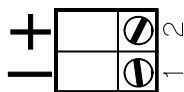

**Attention**

**This connection is polarity sensitive!**

### Connect impulse lines for slave clocks connection.

→ only if recorder is equipped with option module slave clock function"

→ unipolar and bipolar impulses, 12 V - 60 V, 2 - 10 mA.

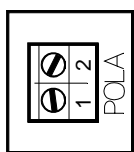

This connection is not polarity sensitive.

### The Installation is now finished.

To program the time recorder see chapter 4 "Getting Started".

If the recorder is to be programmed at a later date, insert the front cover and close the recorder.

# Getting Started

The unit is programmed in the factory for weekly payroll time cards. To set up the time recorder, only three steps are necessary.

1. Open the unit
2. Switch on the unit
3. Close the unit







**Attention**

When you switch on the time recorder an internal adjustment routine begins. Please wait until this procedure, which may take a few minutes, is finished.

The time recorder is ready for operation when this start-up routine is complete and the automatic setting of the clock reached the correct time.

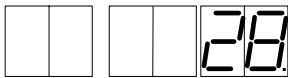
## Switch on the Unit

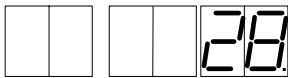
The recorder is provided with a separate power switch. This power switch is located inside the recorder, on the left hand side of the CPU-board.

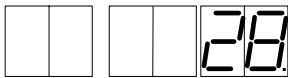
Proceeding					
1.	<p>Remove front cover</p> <p>If the recorder is not yet opened, remove the front cover as described in section "Open the recorder".</p>				
2.	<table border="0" style="width: 100%;"> <tr> <td style="vertical-align: top;"> <p>Switch power switch to position "1".</p> <p>→ Analogue clock is synchronized. Current time is displayed until clock synchronization has finished.</p> </td> <td style="vertical-align: top;"> <p>Example:</p>  </td> </tr> <tr> <td style="vertical-align: top;"> <p>Current date is displayed.</p> </td> <td style="vertical-align: top;"> <p>Example:</p>  </td> </tr> </table>	<p>Switch power switch to position "1".</p> <p>→ Analogue clock is synchronized. Current time is displayed until clock synchronization has finished.</p>	<p>Example:</p> 	<p>Current date is displayed.</p>	<p>Example:</p> 
<p>Switch power switch to position "1".</p> <p>→ Analogue clock is synchronized. Current time is displayed until clock synchronization has finished.</p>	<p>Example:</p> 				
<p>Current date is displayed.</p>	<p>Example:</p> 				

All units have been programmed in the factory with current date and Eastern Standard Time (EST). However, if the recorder was previously switched on, or if your time zone is not Eastern Standard Time, you have to re-set the time and date displayed.

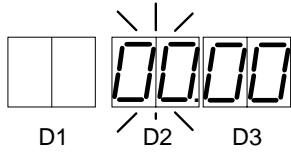

D2 = Hours, D3 = Minutes

For more details on setting date and time, see section "Setting the Time and Date".

3.

Close the unit and locking it.

See section "Close the Recorder".

The recorder is now ready for operation. The current time is shown on the analogue clock and current date is shown on the display.

In order to learn how to handle the recorder, you should do some sample punches with blank time cards. See also section "Punching at the Recorder".

## Programming Panel

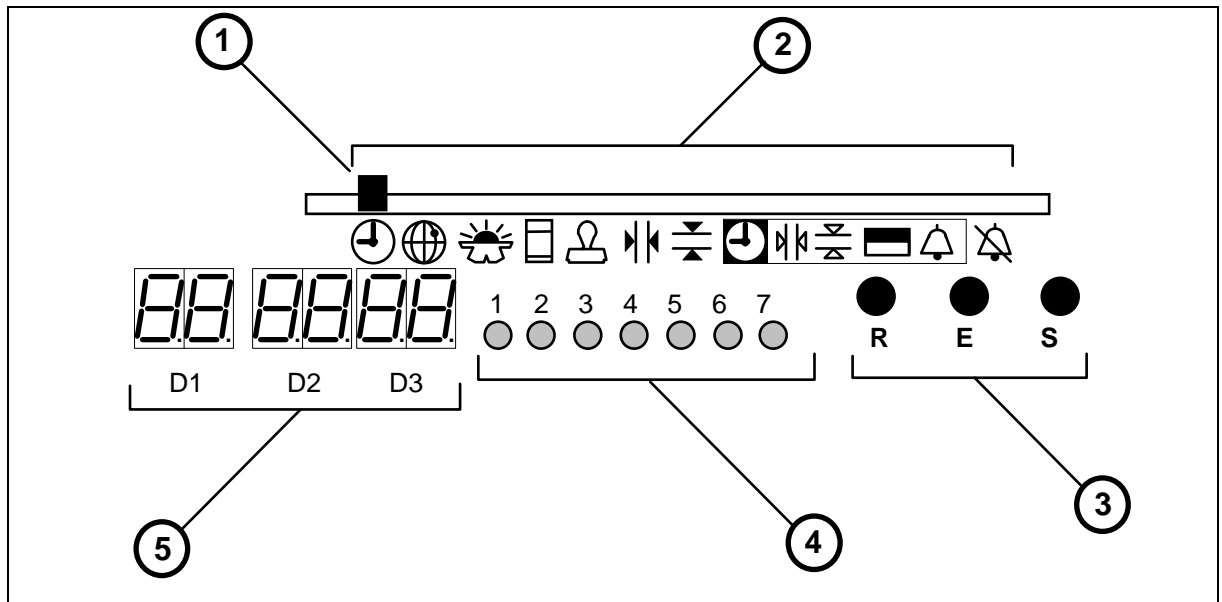

Fig. 11: Programming Panel

- |   |                            |
|---|----------------------------|
| (1) Column pointer                                    | (2) Programming panel      |
| (3) Programming keys <b>R</b> , <b>E</b> and <b>S</b> | (4) Programming-LEDs 1 - 7 |
|   | (5) 6-digits display       |

## Column pointer

Mechanic pointer, marks the current programming symbol and step in programming mode. In normal operation, the column pointer marks the current IN / OUT column in which the time punches will be placed on the time cards.

## Symbols

Chronological order of the programming steps as menu general terms presented as symbols.



→ **Set date and time**

This symbol is not part of the programming routine and is activated by a separate key. See section "Setting Time and Date"



→ **Daylight saving time change-over**

Several modes are available.

See section "Programming - Daylight saving time change-over"



→ This symbol contains no menu item.

Together with the following symbols it indicates the programming of time specific events.



→ **Column change timing**

Determines the times for the column changes per weekday.

See section "Programming - Column change timing".



→ **Card lift / line change timing**

Determines the times for the card lift / line change per weekday.

See section "Programming - Card lift / line change timing".



→ **Ribbon color change**

The print color can be red or black. The times for the ribbon color change can be defined for each weekday.

See section "Programming - Ribbon color change".



→ **Signal operation**

For the control of signal circuit or check of individuals. External signal devices such as bells or horns can be driven via the signal output of the unit. Check of individuals optionally.

See section "Programming - Signal circuit" and "Check of individuals".



→ **Signal out-programming**

Programming of the times to switch on/off signal circuit/check of individuals.

See section "Programming - Signal out programming".

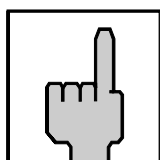

## Program symbols



Language identification



Time card parameters



Time recorder print formats



Column change



Card lift / line change

The programming of individual customer requirements with the above mentioned program symbols is carried out by your local dealer. For further information e-mail us at:

[support@ca.isgus.com](mailto:support@ca.isgus.com)

or

[techsupport@isgus.com](mailto:techsupport@isgus.com)



R

- Change the displayed value  
A value can be changed when flashing in the display. If the key is pressed once, the value will be increased by one. If the key is pressed continuously the value increases in fast mode.



E

- Confirm the values entered.  
Use this key to switch to the next value or next digit in the current menu item.



S

- Skip to next parameter or menu item.  
If not all required values are entered for a menu item, the "S" key will not move you to the next.
- In normal operation column selection by position key

## Programming-LEDs

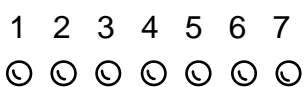

The seven LEDs are for weekday programming. Each flashing LED represents the day for which the necessary change timing needs to be programmed. LED 1 = Monday to LED 7 = Sunday.

## Digital display



D1

D2

D3

- Separated into the fields D1, D2 and D3.  
When the unit is closed, only field D3 is visible.
- In normal operation the current date is displayed. The decimal point flashes always. In case of DCF-connection or slave clock function it goes off with no reception.
- In programming mode the active digit is marked by a flashing LED. A flashing LED indicates that the displayed value can be changed.

## Setting the Time and Date



### Attention

To adjust the analogue clock and/or the internal quartz clock use always the following procedure. It is not sufficient to only set the hands of the analogue clock.

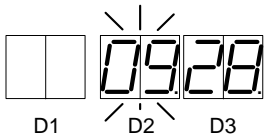
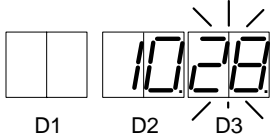
Proceeding		
1.		<p>Press "E" until column pointer marks the symbol for time.</p> <p>Time set is displayed.</p>
2.	<p>Example:</p> 	<p>Enter current hour using "R" .</p> <p>D2 = hours</p> <p>Value range: 00 - 23</p> <p>☞ If you do not want to change the value displayed, continue with step 3.</p>
3.		<p>Confirm the value using "E" .</p> <p>Unit switches to minutes.</p>
4.	<p>Example:</p> 	<p>Enter minutes using "R" .</p> <p>D3 = minutes</p> <p>Value range: 00 - 59</p> <p>☞ Minutes should be set one minute before the desired reference time.</p>
5.		<p>Press "E" when reference time of an external clock corresponds to the time displayed on the unit.</p> <p>Now clock starts with 00 seconds.</p>

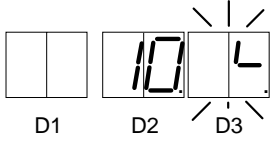
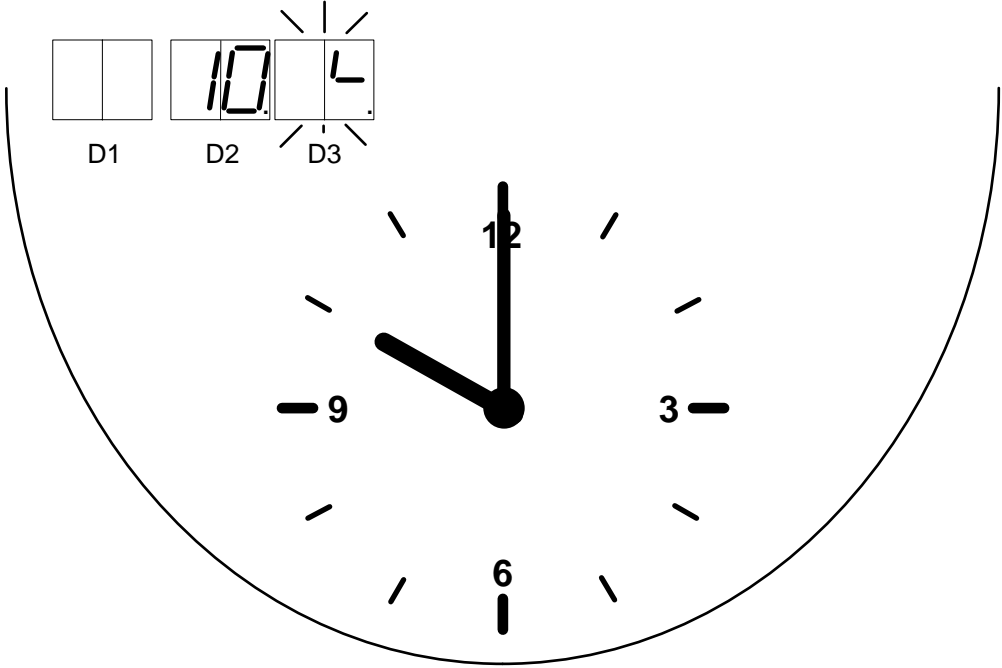
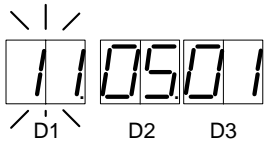
	<p>Example:</p> 	<p>The unit switches to "Synchronize analogue clock".</p> <p>The current hour entered is still displayed. Field D3 indicates that the hands of the analogue clock have to be set.</p>
<p>6.</p>	<p>Set minute hand on 12 o'clock. Set the hour hand on the full hour entered and displayed in D2.</p> <p>☞ In our example: 10 o'clock.</p> 	<p>☞ <b>Set minute hand first</b> and then the hour hand. Both hands can be moved forwards and backwards. The hour hand is coupled with the minute hand. If the minute hand is moved after the hour hand has been set, the hour hand will move as well.</p>
<p>7.</p>		<p>Confirm each setting with "E".</p> <p>The synchronization of the analogue clock will not start immediately. After date has been entered, analogue clock is synchronized.</p>
<p>8.</p>		<p>Enter current date with "R".</p> <p>D1 = day</p> <p>Value range: 01 to 31</p> <p>☞ If you keep "R" pressed, a fast advance of the value range is activated. Example: 31. May 2001</p>

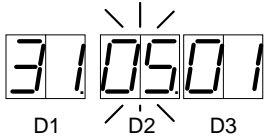
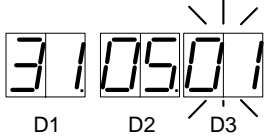
9.		Confirm value using "E". Unit switches to month-entry.
10.		Select current month using "R". D2 = month Value range: 01 to 12
11.		Confirm selection using "E". The unit switches to year-entry.
12.		Enter current year with "R" D3 = year Value range: 00 - 99
13.		Confirm selection using "E".

After the last date entry has been confirmed, the analogue clock is synchronized. Once synchronization has finished the time recorder is in normal operation. Field D3 shows the current date.

---

### Showing or Setting the Time of the Internal Quartz Clock

If you want to check the time of the internal quartz clock, use the procedure "Set Time and Date". The time of the internal quartz clock may differ from the time of the analogue clock. Showing the setting of the internal quartz clock is no manual hand setting.

1. Keep "E" pressed until column pointer marks the symbol for the time.  
The current time is displayed, the hour-display flashes.
2. Is the time setting correct? If yes, confirm setting using "S"
3. Skip the date display by confirming each field using "E".  
After you have pressed "E" three times, you will exit the menu.

After you have changed the internal quartz clock and have confirmed the settings by using "E", manually set the hands of the analogue clock and synchronize the internal quartz clock and the analogue clock.

---

## **Synchronizing the Analogue Clock**

If the time printed on a time card differs from the time on the analogue clock, the analogue clock needs to be synchronized with the internal quartz clock. Use the procedure "Set Time and Date".

Confirm hours and minutes using "E" and set hands of the analogue clock when display shows the symbol "Set hands". Confirm the following date setting using "E".

Re-check the analogue clock by punching a blank sample time card.

---

## **Setting the Date**

Use the procedure "Showing or Setting the Time of the Internal Quartz Clock". Enter the current date values when the column pointer marks the first symbol of the date.

Re-check the clock by punching a blank sample time card.

---

## Programming

After calling up the programming routine the column pointer marks the corresponding symbol on the programming panel. The menu items have to be selected and programmed or confirmed in chronological order. The current program menu is marked by the column pointer.

The different parameters are entered via code-numbers which can be selected using "R".

Using the "S" key you skip to next parameter or menu item. If not all required values are entered for a menu item, the "S" key will not move you to the next.

If you do not want to change any values in a menu item you can check every value using "E".

See also section "Programming panel".

The programming includes the menu items "Daylight saving time", "Column change timing", "Card lift / line change timing", "Ribbon color change", "Signal circuit / Check of individuals (option)".

---

### Calling up the Programming Routine

Calling-up the programming routine is protected by a code number.

Code number:

**4 7 1 1 → Allows the user to program time specific values of the unit.**

If a wrong code-number is entered, the programming mode exits automatically. The programming mode can also be left using "S".



To call up the programming routine, the front cover of the unit must be removed. If the unit is switched off, you must switch it on with the power switch.



#### **Warning!**

Do not touch any live electrical components or parts!  
Only trained staff should service the unit.

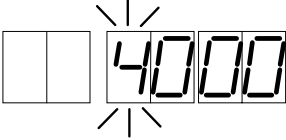
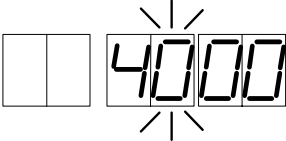
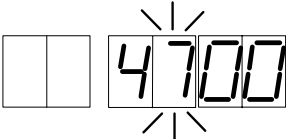
---

Proceeding		
1.		Press "R" (at least 2 seconds) until 4 digits are displayed. The entry of the code number begins with the left flashing digit.
2.		Enter the number using "R". The code-number is "4711"
3.		Confirm selection using "E". Recorder changes to next digit.
4.		Enter next digit using "R" and confirm using "E" Repeat steps 2 and 3 for the other 2 digits.
5.		After the last digit has been confirmed with "E" the column pointer changes to the first menu symbol of the programming routine. →  Daylight saving time

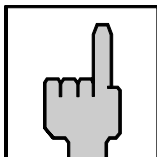

#### Hint

The values used on the next pages are only examples and may differ from your values.



### Daylight Saving Time Change-over

Spring and fall daylight saving time changes can be automatically implemented by the time recorder. You can select an perpetual automatic change-over or you may disable this function using code 00.

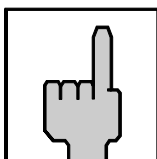

#### Hint

If the change-over is executed according to a freely defined program, all date and time values have to be entered every year resp. after each change-over.

Please note that the change timing can only be entered for the current year. Timing for the current year that are in the past, are automatically deleted by the unit. Entries for the next year are possible from 01.01., 00.00 on.

## Proceeding

1.

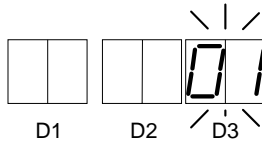

Select change-over mode with "R".

Value range: 00 - 07, 99

Definition:

00 = no change-over

01 = change-over according to CET

- last Sunday in March, 02:00 >> 03:00

- last Sunday in October, 03:00 >> 02:00

02 = change over according to CET

- last Sunday in March, 02:00 >> 03:00

- 4th Sunday in October, 03:00 >> 02:00

03 = change-over according to GMT

- last Sunday in March, 01:00 >> 02:00

- last Sunday in October, 02:00 >> 01:00

04 = change-over according to GMT

- last Sunday in March, 01:00 >> 02:00

- 4th Sunday in October, 02:00 >> 01:00

05 = change-over according to EEZ

- last Sunday in March, 03:00 >> 04:00

- last Sunday in October, 04:00 >> 03:00

06 = change-over according to EEZ

- last Sunday in March, 03:00 >> 04:00

- 4th Sunday in October, 04:00 >> 03:00

07 = change-over according to USA

- 2nd Sunday in March, 02:00 >> 03:00

- 1st Sunday in November, 03:00 >> 02:00

99 = change-over freely programmed

☞ When selecting code "00" to "07",  
continue with step 4

☞ When selecting code "99" continue with  
step 2.

2.

Confirm selection using "E".

### Only for freely programmed change-over

D1 = **01** = Change-over from normal- to  
daylight saving time > **Date** <

D1 = **02** = Change-over from normal- to  
daylight saving time > **Time** <

D1 = **03** = Change-over from daylight saving to  
normaltime > **Date** <

D1 = **04** = Change-over from daylight saving to  
normaltime > **Time** <

D2 = day / hour

D3 = month / minute

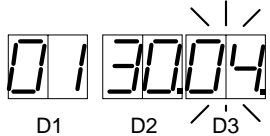
3.		<p>Select date in field D2 , value range 00 - 31 resp. hour, value range 00 - 23 with "R"</p> <p>Select month in field D3 , value range 00 - 12 resp. minute, value range 00 - 59 with "R"</p> <p>Confirm each field using "E".</p> <p>Field D1 will be increased automatically.</p>
4.		Press "S" for next menu item.



### Column Change Timing

In this menu the time has to be entered from which on the punching shall be printed in the corresponding column.

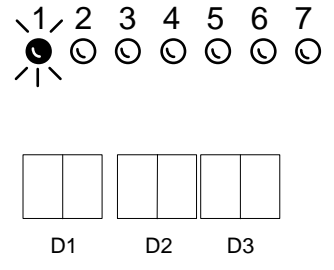
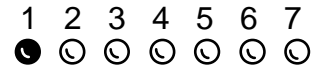
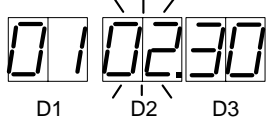
Proceeding		
1.		<p>Per weekday one value for the column change must be defined.</p> <p>Select weekday using "R".</p> <p>The weekdays are indicated by the LEDs. If the menu item "Column change timing" is selected, the first LED flashes.</p> <p>1 = Monday 2 = Tuesday 3 = Wednesday 4 = Thursday 5 = Friday 6 = Saturday 7 = Sunday</p>
2.		<p>Confirm weekday using "E".</p> <p>The LED lights permanently.</p>
3.		<p>D1 = column, 01 = 1. punching column</p> <p>Define <b>hour</b> in field D2 using "R". Value range: 00 - 23</p> <p>Define <b>minute</b> in field D3 using "R" Value range: 00 - 59</p> <p>Confirm each field using "E".</p>

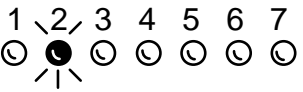
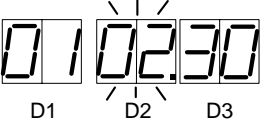
4.		After the last value has been entered, press "S".
5.		Select next weekday using "R" and confirm with "E".
6.		<p>Repeat steps 2 to 4 for the remaining weekdays.</p> <p>☞ If the time values for the column changes have already been programmed and you only want to change a single value of a certain weekday you need not to advance through all weekdays.</p> <ol style="list-style-type: none"> <li>1. Select desired weekday using "R".</li> <li>2. Confirm weekday using "E" The value to be changed is displayed.</li> <li>3. Enter new time using "R".</li> <li>4. Quit setting by pressing "S" and select next weekday or continue as described under step 7.</li> </ol>
7.		<p>Quit menu "Column change timing" using "S" and advance to next menu item "Card lift / line change timing".</p> <p>☞ When time values are entered for the first time respectively after a reset, all values for each weekday have to be entered before the menu can be left. The times of the previous day are offered as default values for the following day. When last time value is confirmed with "E", the menu can be left using "S".</p>

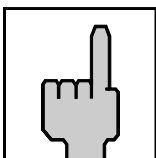

**Hint**

If another time value than 00:00 h is programmed, e.g. 02:30 h, shift, overlapping the end of the day can be printed in the column of the previous day.



## Card Lift / Line Change timing

In this menu the time has to be entered from which on the punching shall be printed in the corresponding line.

Two time values must be programmed.

- Time value for the start position of the card lift in the upper print field.
- Time value for the end position of the card lift in the lower print field.

The position for any punching between the two values is defined by the unit automatically.

Any punching beyond the time range defined will be printed in the same height as start or end position.

The programmed values are valid for all weekdays.

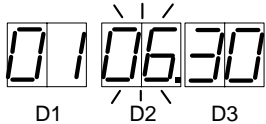
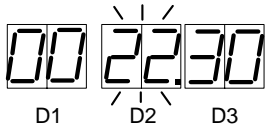
Proceeding		
1.		D1 = print field 01 = upper print field  Define <b>hour</b> in field D2 using "R". Value range: 00 - 23  Define <b>minute</b> in field D3 using "R". Value range: 00 - 59  Confirm each field using "E".
2.		D1 = print field 00 = lower print field  Define <b>hour</b> in field D2 using "R". Value range: 00 - 23  Define <b>minute</b> in field D3 using "R". Value range: 00 - 59  Confirm each field using "E".
3.		Quit menu "Card lift / line change timing" using "S" and advance to next menu item "Ribbon color change".



## Ribbon Color Change

The unit offers the possibility to change between the colors black and red for the punching. The bi-colored ribbon enables the time recorder to highlight in red ink any attendance irregularities e.g. lateness, coretime infringement, medical visits.

Via the menu "Ribbon color change" the point of time is programmed when the ribbon color change shall be executed.

These time values must be programmed for all weekdays. Up to 8 time values per weekday can be programmed in any order. The values will automatically be ordered chronologically by the unit.

The color set remains active until another ribbon color change is executed according to the time value programmed.

If no ribbon color change is programmed, all punchings will be printed in black as this color is pre-programmed for the printer in the factory.

Proceeding		
1.		<p>Programming proceeding see also section "Column change timing".</p> <p>Per weekday 8 time values for the ribbon color change can be defined.</p> <p>Select weekday using "R".</p>
2.		<p>Confirm weekday using "E".</p> <p>The LED lights permanently.</p>
3.		<p>D1 = Ribbon color D2 = Hours D3 = Minutes</p> <p>Define <b>color</b> in field D1 using "R". Value range: 01 = black, 02=red</p> <p>Confirm field using "E".</p>
4.		<p>Define <b>hour</b> in field D2 using "R". Value range: 00 - 23</p> <p>Define <b>minute</b> in field D3 using "R". Value range: 00 - 59</p> <p>Confirm each field using "E".</p>

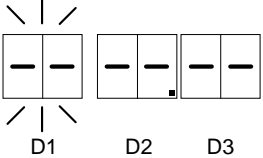
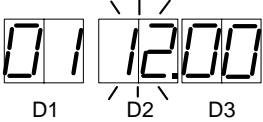
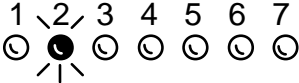
5.		<p>Define <b>color</b> in field D1 using "R". Value range: 01 = black, 02=red Confirm field using "E".</p>
6.		<p>Define <b>hour</b> in field D2 using "R". Value range: 00 - 23 Define <b>minute</b> in field D3 using "R" Value range: 00 - 59 Confirm each field using "E".</p>
7.		<p>After the last value has been entered, press "S".</p>
8.		<p>Select next weekday using "R" and confirm with "E".</p>
6.		<p>Repeat steps 3 to 6 for the remaining weekdays.</p> <p>☞ If the time values for the color changes have already been programmed and you only want to change a single value of a certain weekday you need not to advance through all weekdays.</p> <ol style="list-style-type: none"> <li>1. Select desired weekday using "R".</li> <li>2. Confirm weekday using "E"</li> <li>3. Select time value to be changed → advance using key "E"</li> <li>4. Enter new time using "R".</li> <li>5. Quit time entry for this weekday using "S" To change further values on other weekdays, repeat step 1 to 4</li> </ol>
7.		<p>Quit menu "Column change timing" using "S" and advance to next menu item "Signal operation".</p>

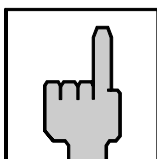

### Hint

Two identical time values for one weekday (e.g. 17:00h for black and red print) cannot be programmed.

## Delete Values for Ribbon Color Change

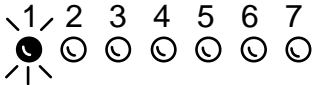
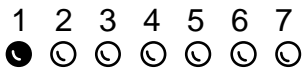
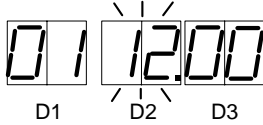
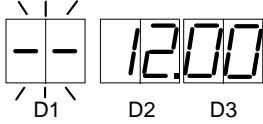
Proceeding		
1.		Call up Programming routine using "R". Select menu "Ribbon color change" using "S".
2.		Select weekday using "R".
3.		Confirm weekday using "E".
4.		Select time value to be deleted using "E"
5.		To delete the value displayed, enter "--" in field D1 using "R" Confirm the deletion command using "E".

## Signal Operation

The item signal operation contains two functions: signal circuit and check of individuals.

The PERFECT time recorder is provided with a low power signal output for the controlling of an external relay. To this external relay it is possible to connect an external signal device.

If the unit is provided with the function check of individuals, the function signal circuit is no longer available. See section "check of individuals".

Each function is separated in 2 parts and each part has its own menu symbol:

- signal times for the signal circuit / check of individuals
- signal out-programming

In the menu item "Signal times", the times for signals on a weekday are programmed. To switch off the signal for a longer period, you can define this period in the menu "Signal out-programming".



## Signal Times for Signal Circuit

External signal devices, e.g. a horn for the organization of breaks or the plant illumination can be switched on and off at defined times by the programming of signal circuit.

Contrary to the check of individuals the signal circuit works person-independent, that means the release of the signal completely takes place according to defined time intervals.

The settings for signal time and duration for the signal circuit can be determined separately for each weekday, same as in the menu "Ribbon color change".

Up to 16 signal times can be programmed per weekday,

If no times are entered for one weekday, e.g. on Saturday or Sunday there will be no signal in the corresponding day.

Programming proceeding see section "Column change timing".

The signal duration will be selected in field D1 and is in seconds.

### Change or delete signal times

All time values programmed can be changed or deleted at any time.

1. Call up Programming routine → key "**R**".
2. Select menu "Signal times for signal circuit" → key "**S**".
3. Select weekday with values to be changed → key "**R**".
4. Select value to be changed → advance with "**E**".
5. Change signal duration and/or signal time → key "**R**".  
To change further values on the same weekday repeat steps 4 and 5.
6. Quit entry for this weekday → key "**S**".  
To change any values on other weekdays repeat steps 3 to 6.
7. Quit menu "Signal times for signal circuit" → key "**S**".
8. Quit programming routine → advance to the end of the programming panel with "**S**".

If you want to delete single values of a weekday, proceed as described above. To delete the time value displayed, select "--" in the field D1 with the key "**R**". Confirm the deletion command with "**E**". Now the next time value programmed is displayed.

Now the menu can be left as described or new time values can be entered.



## Signal out-programming

The time values programmed in the menu "Signal times for signal circuit" are valid for the entire year. In the menu "Signal out-programming" time periods can be defined in which the signal shall be switched off automatically, e.g. holidays, bank holiday, etc.

The dates to switch on and off the signal must be programmed. If the signal shall only be switched off for one single day, it is enough to program the date the signal is switched off. If no date to switch on the signal is programmed, the signal will be switched on the following day. Up to 16 dates can be programmed.

The dates can be entered in any order, it is not necessary to order the dates chronologically. But the date to switch off the signal must be followed by the date to switch on. All dates will be ordered chronologically by the unit.

Programming proceeding see section "Column change timing".

The change criterion is indicated in field D1. 00 = signal "OUT", 01 = signal "ON".

Field D2 = day, field D3 = month.

### Change or delete signal out-programming

The date values programmed can be changed or deleted at any time.

1. Call up Programming routine → key "**R**".
2. Select menu "Signal out-programming" → key "**S**".  
→ The first date (chronologically ordered) is displayed.
3. Select date with value to be changed → advance with key "**E**".
4. Change criterion on/off and/or date → key "**R**" and "**E**".  
To change further values repeat steps 3 and 4.
5. Quit entry and menu → key "**S**".  
Programming routine is left.

If you want to delete single values, proceed as described above. To delete the value displayed, select "--" in the field D1 with the key "**R**". Confirm "--" the deletion command with "**E**". The next time value programmed is displayed. Now the menu can be left as described above or new values can be entered.

After leaving the menu item "signal out-programming" with "**S**" the programming routine is left automatically. The unit executes an adjustment where the new programmed values are set.



### **Check of individuals (Option)**

The functions signal circuit and check of individuals exclude each other. With the programming of the check of individuals external signal devices, e.g. lamp, horn in the lodge, are switched on to variable times. The times between the signal activation are controlled by a random number generator and not by time values. The percentage programmed is basis for the random number generator to activate the signal devices according to an internal selection procedure. Programming the "Check of individuals" replaces the menu "Signal times for signal operation", with same menu symbol. If the menu "Ribbon color change" is left, the value for the check of individuals can be programmed immediately. For programming only a percentage in field D3 has to be selected. If the value "00" is entered, the function "Check of individuals" can be switched off completely.

---

## Punching at the Recorder

### Time card handling

With all models of time recorder, the card side on which the clock punch is to be printed must be facing towards the user.

1. Insert the time card into the card funnel until the card comes to a stop. Wait for the time recorder to finish printing.
2. Remove card from the time recorder.

If your company uses both sides of the time card, the employees must ensure that they are punching on the correct side of the time card to prevent the over-printing of punches.

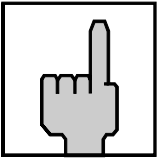

#### Hint

Do not pull the time card out of the time recorder while it is printing. This could cause the printing on the time card to be unreadable.

---

### Requirements for Trouble Free Time Recording

- Always store time cards in a dry place. Humidity can cause the time cards to expand so that they will not fit into the time recorder.
- Keep the time cards in good condition and avoid mishandling damage, such as corner bending, folding, and tearing.
- Protect time cards against contamination from such as dirt, dust, and oil.
- Do not expose time cards to direct sunlight.
- Keep new and used time cards in the card box in which they were supplied. .
- Due to tolerances in the printing of the time cards, the position of the print may be changed. Therefore check the printing on the time card from time to time, and if necessary, adjust the print position by means of the stored adjustment routine.
- Have your time recorder serviced once a year by your local dealer.

---

## Punching with Standard Time Cards

The punching is printed in columns related to the clocking day. The card has no line separation.

Each punching column is one punching day of the period.

All punchings of one day are printed in the same vertical column. The column change is executed automatically by the unit.

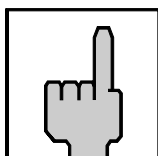

### Hint

The position key has no function in punching operation!

---

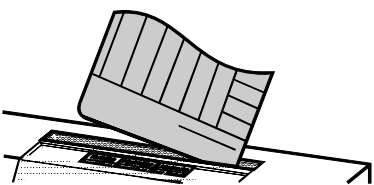
Proceeding	
1.	 <p>Insert card into card funnel. Press card slightly down until clocking is released.</p>
2.	<p>Remove card from unit.</p>

---

## Standby Operation (Option)

In order to maintain the normal operation during power failure the time recorder must be provided with a standby battery pack for the printer head.

With this option, the time recorder will print up to 300 registrations over a power outage period of 24 hours.

In case of power failure, the time recorder switches automatically to standby operation. Standby operation is indicated by a flashing line in the right segment of the digital display.

To save battery capacity all sub-functions, e.g. adjustment, programming, test runs etc. will be disabled. Ribbon changing can be done while the time recorder is in standby power mode.

---

## Change of Fuse for Signal Output

The low power signal output is protected by a replaceable fuse.  
This fuse only effects the signal output and is not relevant for the whole unit. The fuse in the external power supply is meant for the unit itself.  
Use only fuses with the same technical data. → See appendix A "Technical Specifications".



### Attention

Before changing the fuse, switch off the unit and disconnect the power supply.

1. Open the unit with the key and remove the front cover.
2. Disconnect the power supply (see illustr.).
3. Switch off the unit.
4. Slightly pull out the fuse from the fuse plug (see illustr.).
5. Take the new fuse and insert it into the fuse plug.  
Polarity need not be observed.
6. First connect the power supply and then switch on the unit.
7. Check the display. Current date must be displayed.

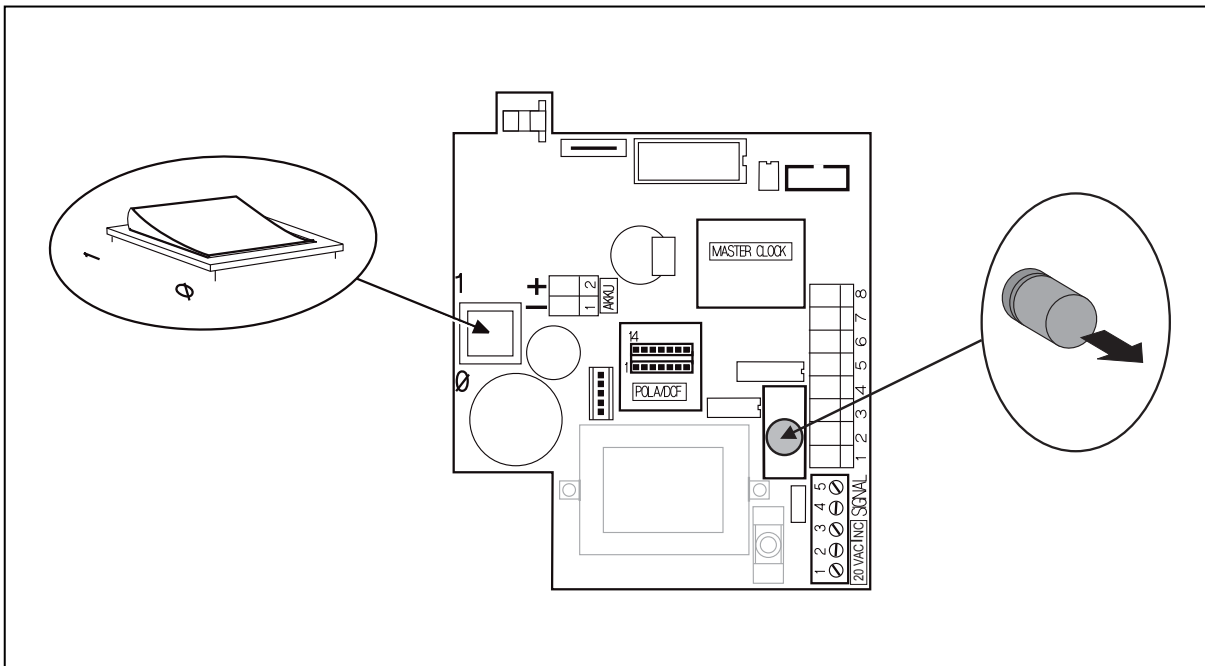

Fig. 12: PC-board with power switch and fuse for signal output

## Error messages





Any error at the time recorder is indicated by a combination on the display. If the problem cannot be solved, please contact your local dealer or e-mail us at:

**support@ca.isgus.com**

or

**techsupport@isgus.com**

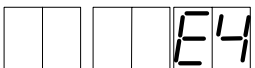
To avoid any confusion with the date, all error messages begin with the letter E.

Display	Reason	What can be done
	P-Module, Error in resident memory. → Punching at the recorder is no longer possible.	Switch unit off and on. If the error message is still displayed, the P-Module has to be changed. → Please contact service technician.
	RTC-module, error in real time clock component. → Punching at the recorder is no longer possible.	Switch recorder off and on. If the error message is still displayed, the RTC-module has to be changed. → Please contact service technician.
	Error in synchronization of the card lift, mechanical error. → Punching at the recorder is no longer possible.	Switch recorder off and on. If the error message is still displayed → Please contact service technician.
	Printer head is blocked or runs hard. → A piece of paper may be pinched in the card guide.	Switch off recorder. Remove metal rear cover, swing-out programming panel and check card guide, Switch on unit. If the error message is still displayed → Please contact service technician.
	Program error → can only happen when the recorder is switched on.	Switch recorder off and on. If the error messages is still displayed, the EPROM has to be changed. → Please contact service technician.

## Adjustment Routine

The position of the punching on the time card is defined when programming the unit. Generally in the factory. But it may happen that the punching is not printed exactly in the right position due to manufacturing tolerance and especially card tolerances. With the adjustment routine the position of the punching on the time card can be adjusted in vertical and horizontal direction and adapted to new card dimensions. The clocking can be adjusted within -5.0 mm and +4.9 mm in both directions, from the left to the right and from top to bottom.

The adjustment is executed via the adjustment value which must be between 00 and 99. This adjustment value corresponds with the dimensions of the unit printed on this page. The adjustment value pre-programmed ex factory is 50 and this value means no change in print position. Changes are in steps of 0.1 mm.

Minimum dimensions of the card:

- left card edge                      3.5 mm
- bottom line                         16.5 mm

---

### Card lift / Line change

To check the position, the first punching of a payroll period is printed into the first column and the first line.

The position can be changed by pressing "R" (+) and "E" (-) in 0,1 mm steps.

---

### Column change

The adjustment of the column change resp. the horizontal position of the punching identical to the adjustment of the card lift / line change but the left card edge is used as reference line.

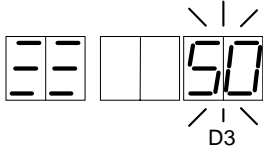
Proceeding	
1.	Unit is switched on.
2.	Press "E" first, then "S". Keep both keys pressed for about 2 seconds until display shows the adjustment value for card lift.
3.	<div style="display: flex; align-items: center;">  </div> <p><b>Adjust card lift / line change</b></p> <p>Display = Adjustment value 50 = 0 mm, no correction</p> <p>Value range:    00 - 99</p>

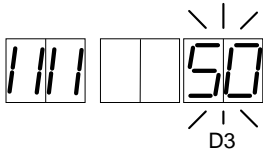
		<p>Shift punching upwards using "R" (+). ☞ The distance between bottom line and punching is increased.</p> <p>Shift punching downwards with "E" (-). ☞ The distance between bottom line and punching is decreased.</p>
4.		Insert time card and make a sample punching.
5.		<p>Repeat steps 3 and 4 until punching is printed in correct position.</p> <p>Press "S" to confirm and to continue with adjustment of the column change.</p>
6.		<p><b>Adjust column change</b></p> <p>Display = Adjustment value 50 = 0 mm, no correction</p> <p>Value range: 00 - 99</p> <p>Shift punching to the right with "R" (+). ☞ The distance between left card edge and punching is increased.</p> <p>Shift punching to the left with "E" (-). ☞ The distance between left card edge and punching is decreased.</p>
7.		<p>Repeat adjustment and sample clocking until the horizontal position of the clocking is correct.</p> <p>Press "S" to quit adjustment routine.</p>

## Changing the Ribbon

To change the ribbon the programming panel has to be swung out. The column pointer has to be moved to the park position.

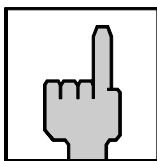

### Hint

The ribbon used in the unit is a special ribbon. If you want to order further ribbons, please contact your local dealer or e-mail us at:

[sales@ca.isqus.com](mailto:sales@ca.isqus.com)

or

[sales@isqus.com](mailto:sales@isqus.com)

## Proceeding

1. The time recorder is switched on.
2. Press "R" and "E" simultaneously and keep these keys pressed for 1 second.  
→ Column pointer moves to the park position right of the card funnel.
3. Press the locking straps on the left and right side of the card funnel slightly towards the recorder and swing out the programming panel.
4. Lift up and remove the ribbon cassette.



### **Warning!**

Depending on use, the printer head may be very hot.  
Touching the printer head could cause burns.

---

5. Insert new ribbon cassette and push slightly down.  
Tighten the new ribbon by winding the red ribbon tightening knob in the direction indicated by the arrow on the cassette. Position the free guide of the ribbon in the direction of the printer head.  
Make sure that the ribbon guide is inserted in front of the printer head and that the ribbon is not twisted or creased.  
The ribbon cassette must engage into the left and right locking straps.
6. Check that the ribbon fits between the printer head and the ribbon guide.  
Tighten the ribbon again.
7. Swing in the programming panel.  
Press "R" and "E" once again, see step 2.  
→ The column pointer moves back to initial position.
8. Close the time recorder.

---

## Cleaning the Time Recorder

The main problem is dust on electronic components.

In order to maintain the physical appearance of the time recorder, the cover must be occasionally cleaned.

The cleaning intervals depend on the operating conditions and the location.

When cleaning the time recorder with cloths, please observe the following recommendations:

- Use only rags moistened with water or a soap-free detergent.
- Do not use any detergent spray or wet rags.
- Use only soft detergents without solvents of any kind.
- Make sure to thoroughly dry all components after cleaning.

## Technical Specifications

<b>Dimensions</b>	Height: 280 mm (11.02 inches) Width: 220 mm (8.67 inches) Depth: 195 mm (7.68 inches)
<b>Weight</b>	3 kg
<b>Supply voltage</b>	20 V AC +/- 10 % 50 / 60 Hz
<b>Current consumption</b>	max. 800 mA
<b>Power consumption</b>	max. 45 VA
<b>Protection type</b>	IP 20
<b>Protection class</b>	I
<b>Ambient temperature</b>	5° C to 40° C (no direct sunlight)
<b>Relative humidity</b>	max. 80 %, non condensing
<b>Connection</b>	- Standby operation (Option) - Slave clock function (Option) 12-60V, 2-10mA, unipolar/bipolar impulses - Master clock (Option), Output 12V, 50mA max. - Signal circuit, see item "Signal operation"
<b>Determination of time</b>	Quartz, Pola
<b>Signal circuit</b>	Low power signal output: 15 V DC, 50 mA Fuse: 50 mA T
<b>Printer</b>	9 dot matrix printer
<b>Battery pack</b>	Nominal voltage 12 V Nominal capacity 600 mAh Discharge temperature: -20 to + 60° C Storage temperature: -30 to + 50° C Weight: 300 g

### Plug-in power supply unit

<b>Supply voltage</b>	120 V / 20 V AC +/-10 % 50 - 60 Hz
<b>Rated output</b>	permanent 16 VA / max. 45 VA

---

## Local Sales and Service Dealer

Dear Customer,

ISGUS would like to thank you for your business and to assure you that you have purchased the world's finest industrial time recorder.

If you have any questions or problems with your time recorder, please contact your local dealer or e-mail us at:

**support@ca.isgus.com**

or

**techsupport@isgus.com**

Our service advisors will contact you within 48 business hours and assist you in resolving any troubles you may encounter.

Should you wish to order further time recording systems, please contact your local dealer or e-mail us at

**sales@ca.isgus.com**

or

**sales@isgus.com**

Please record the following information and store this manual in a safe place. You will require it when contacting your dealer or communicating with ISGUS.

<b>Time Recorder</b>	Model Number	_____
	Serial Number	_____
	Date Purchased	_____

<b>Description of Use</b>	Number of Employees	_____
	Type of time cards	_____

### Local Dealer

Company \_\_\_\_\_

Contact \_\_\_\_\_

Address \_\_\_\_\_

\_\_\_\_\_

\_\_\_\_\_

Telephone \_\_\_\_\_

Fax \_\_\_\_\_

e-mail \_\_\_\_\_







ISGUS GmbH  
Oberdorfstraße 18-22  
DE - 78054 Villingen-Schwenningen  
Tel. 0 77 20 / 3 93 - 0  
Fax 0 77 20 / 3 93 - 1 84  
[www.isgus.de](http://www.isgus.de)  
[info@isgus.de](mailto:info@isgus.de)



Ahead in Time - ISGUS Time Management